



**COMHAIRLE CONTAE FHINE GALL  
FINGAL COUNTY COUNCIL**

**Appendix 9**

**General Specification for  
Public Lighting Installations in Residential, Industrial  
and Commercial Developments**

**August 2017**



## **INTRODUCTION**

It is the policy of Fingal County Council and normally a condition of Planning Permission that in any new residential and industrial development to be taken-in-charge a Developer must install public lighting to a design approved by the Council. This work normally includes the supply and installation of all ducting, cabling, service-pillars, columns, lanterns and other necessary electrical equipment and control gear as specified by the Council and generally elaborated in this document. It is recommended that the Developer employ an experienced PL contractor to execute the works.

The Public Lighting Section (PLS), part of the Operations Department of Fingal County Council, has responsibility for public lighting matters in the County. The office address is: Civic Offices, Grove Road, Blanchardstown, Dublin 15. The general contact number for the Section is 8905870.

In order to comply with national requirements the developer's electrical contractor must be a registered member of the relevant Electrical Safety Supervisory Body (ESSB) designated by CER as the approved regulatory body for the Electrical Contracting Trade. ETCI Completion Certificates will be required for each supply point requiring ESB connection and only certificates from Qualified Certifiers will be accepted.

A lighting installation will only be taken in charge when it complies fully with the agreed design and electrical specification issued by the Council and fully electrically certified. All installations will be subject to inspection by the Public Lighting Section during works and on completion. The Developer is completely responsible for ensuring that all aspects of the agreed lighting design are completed to the Council's satisfaction.

Developments intended to be privately managed are also normally required by Planning Permission to install an approved lighting scheme. The PLS can provide a design for such developments but should a Developer decide to proceed with a design utilising equipment and installation methods of their own choosing the Developer/Management Company will be responsible at their own expense for all works that may be required to make the installation compliant with taking-in-charge standard in relation to light levels, energy efficiency and maintainability of installation should a request be made subsequently for the development to be taken in charge.

**Developers should note that lighting installations powered via landlord-supplies will NOT be taken in charge; such supplies will require conversion to Unmetered Supply in public ground and at the expense of the Developer/Management Company prior to taking in charge.**

No existing public lighting affected by the Developer's works, whether on Fingal County Council columns or ESB poles, shall be altered or removed without the prior express agreement of the Council; and in such cases the Developer will normally be required to have the agreed permanent lighting operational in advance of any such removal or alternatively install at his own expense temporary public lighting as agreed with the Council. The Developer will be liable for any costs incurred by the Council in remedying any unauthorised removal/modification of street lighting.

## **GENERAL PROCEDURE**

### **(a) Lighting design provided by Public Lighting Section (PLS).**

To facilitate provision of an appropriate lighting design the PLS will require a site layout in AutoCad format, including the Planning Reference Number, which should be e-mailed to:

[lighting@fingal.ie](mailto:lighting@fingal.ie)

The site layout must show clearly road names, house numbers, ESB LT distribution pillars, footpaths, verges, driveways and any features that may require special consideration for lighting, e.g. shared surface areas, cycle tracks, chicanes and other traffic calming measures. Where necessary the layout shall clearly distinguish between areas to be taken-in-charge by Fingal County Council and areas which will be in the care of any private management company.

The Council's policy is to minimise energy usage and maintenance costs in lighting installations subject to achieving appropriate lighting levels. With a balance of these objectives in mind, the Electrical Section will provide a public lighting layout mapped on the site drawings provided by the Developer. Column positions, nominal height of columns, lantern types, cable sizes, underground circuits and column numbering scheme will all be indicated.

A Developer proposing to use an alternative lantern to that indicated on the Council lighting plan must demonstrate that the alternative is at least as effective and energy efficient as that originally specified by the Council.

**(b) Lighting design by Developer.**

Alternatively a Developer may submit a public lighting plan to PLS for approval and agreement prior to commencing installation. Without prior approval the Council may require the Developer to modify equipment or the installation at his own expense in order to comply with Council requirements. The main requirements for any residential development lighting plan submitted for approval to PLS are as below.

- 1) It is a requirement that LED light sources are used in all new lighting installations, both public and private. The design must utilise LED lighting from reputable manufacturers and with an S/P ratio no greater than 1.6. Fingal County Council is on a framework for the procurement of LED luminaires for both residential and distributor roads. Based on this framework, the approved list of LED luminaire manufacturers are:
  - a. CU Phosco Lighting
  - b. Holophane Lighting
  - c. OrangeTek Lighting
  - d. Philips Lighting
  - e. Swarco
  - f. Urbis Schröder Ltd
  - g. ZG Lighting Ltd (formally Thorn Lighting Ltd)

LED luminaires which are not manufactured by the above may also be used in new installations but must comply with the specifications of the framework-available on request. The Developer must submit data for the proposed fittings on the LED Data Form included with this document.

- 2) The residential lighting design will usually be based on Illuminance calculations and shall achieve P4 Class lighting in accordance with BS 5489-1:2013 calculated in accordance with IS EN 13201-3:2015 and using a maximum grid spacing of 1.5m x 1.5m. The design shall be submitted based on use of LED lighting mounted on 6 metre columns. The LED light source shall have a 'neutral white' colour temperature and post-top mounting of lanterns is the preferred option. For access roads and local distributor roads consultation with PLS will be required for advice on the appropriate lighting class to be achieved.
- 3) The design submitted shall include an Isolux contour plot ranging down to minimum calculated illuminance.

- 4) The overall maintenance factors used in the design calculations for LED light sources shall be calculated using a Luminaire Maintenance Factor (LMF) of 0.84 for luminaire mounting heights of 6 metres or less, and a LMF of 0.92 for luminaire mounting heights of more than 6 metres, as shown in Annex B Table B.1 of BS 5489-1:2013.
- 5) All ducts, columns and PL distribution pillars must be located entirely in areas which are designated to be taken in charge, i.e. public ground, by the Council. No ducts shall be run in or through lands not scheduled for taking in charge.
- 6) Ducts shall be arranged to run longitudinally under verges/footpaths. Columns and PL distribution pillars are to be placed in the rear of footpaths, in grassed verges or other un-planted areas as appropriate to road/verge housing layouts.
- 7) Other than road crossings, which must run perpendicularly from kerb-kerb/verge-verge, no lighting duct must be run longitudinally in a road.
- 8) Electricity supplies must be Unmetered type with PL pillars arranged as per ESB Networks National Code of Practice for Customer Interface. All PL columns and pillars shall be sited at least 2m from ESB source pillar. PL pillars may be placed immediately adjacent to the first column of a circuit fused from that pillar. In all cases ducting between PL pillar and ESB pillar must comply fully with ESB Interface requirements.
- 9) To comply with Unmetered Supply requirements the maximum connected load at a PL pillar must be no greater than 2kVA. The design submitted must indicate the proposed circuit arrangements including cable and fuse sizing.
- 10) The preferred underground cable is NYCY type with concentric screen/protective conductor. Where SWA cable is used a separate protective conductor must be included in the cable and the armour must be bonded using appropriate commercial bonding kits.
- 11) **FINGAL TREE POLICY:** Trees must be placed so that their drip line when mature will be a minimum of 5 metres from any column; trees should not be grouped or clustered in such a way as to impede the effective lighting of the development when mature.
- 12) Cable routes across a green space shall be aligned along the perimeter of the space in the interest of safety by maximising traceability of cable route and minimising likelihood of damage which might occur should later excavation/landscaping of the space take place.
- 13) The Council does not accept the use of illuminated bollards as a means of providing public lighting.
- 14) Columns must be manufactured in accordance with IS EN 40, tubular/octagonal steel style with galvanised finish. Concrete used to secure column roots should not extend above level of the lower edge of cable entry.
- 15) Columns placed in 'shared surface' areas may require kerbed refuges or other barriers to prevent impacts from manoeuvring vehicles. Columns exposed to the likelihood of impact from vehicles will not be taken in charge by the Council.
- 16) Individual Photoelectric Control Unit (PECU) are to be used for switching lights to operate on dusk-dawn profile, which shall be 35 lux on/18 lux off.

Any conflicts between the lighting design and site conditions, whether related to construction difficulties or health and safety issues, must be notified to the Electrical Section for prior agreement on modification as any unapproved modifications will not be accepted for taking-in-charge.

### **WARRANTY PERIOD**

**The Developer is liable for replacement of any equipment which fails in normal service or otherwise needs corrective action if detected by the Council or their agents during a period of one year from the date of connection completion by ESB Networks.**

## **ELECTRICITY SUPPLY, ESB NETWORKS and CERTIFICATION REQUIREMENTS**

### **1. Supply Agreement**

For public lighting that will be taken in charge a Developer does not need to establish a Supply Agreement as the Council has a Supply Agreement in place for such lighting.

### **2. Connection Agreement**

A formal application to ESBN is required for each new public lighting supply point. The application process is normally completed by the Council for lighting that will be taken in charge. ESBN requires prior payment for each new connection point and the Developer is liable for this payment.

The normal procedure for obtaining a Connection Agreement is:

- (a) Fingal County Council will make the necessary application to ESBN for the number of supply points required based on the agreed Lighting Plan.
- (b) ESBN will issue to Fingal County Council a TMRPN for each supply point in the installation and an invoice for prepayment of the contributions required.
- (c) Fingal will issue an Invoice to the Developer for the ESBN payment plus a fee to cover Fingal administration and inspection costs. **PROMPT PAYMENT OF THIS INVOICE WILL AVOID UNNECESSARY DELAY IN CONNECTION OF SUPPLY POINTS.**
- (d) The Council will pay in full the contribution amount invoiced by ESBN.

### **3. Certification**

When a lighting installation has proceeded to the stage of being ready for supply connection the Developer must provide the forward information to the Council:

#### **(a) Fingal County Council Supply Point Duct Completion Certificate**

A blank of this form is attached to this specification. This certificate is required to confirm that all ducts necessary for ESBN to lead cables into the supply point are clear and fitted with suitable draw rope. The Developer is liable for all attendance on ESBN should this duct subsequently be found to be missing/defective or otherwise unsuitable for ESBN use.

#### **(b) ETCI Completion Certificate for Electrical Installations**

To enable ESBN to complete supply connection the appropriate ETCI completion certificate must be completed on-line by the Developer's electrical contractor. This will require inclusion of the relevant TMRPN assigned by ESB. The PLS will release the relevant number to the Developer's contractor subject to PLS staff completing a pre-connection inspection to confirm compliance with Council requirements. The Developer/Electrical Contractor must contact PLS to request this inspection. Subject to the installation being deemed satisfactory and the Developer/Electrical Contractor having corrected any notified defects, the PLS will notify the relevant TMRPN to the Contractor which will enable submission of the Completion Certificate to ESBN. In all cases the Developer/Electrical Contractor must provide Customer copies of all Completion Certificates.

#### **(c) Post Connection Testing**

To fully comply with testing requirements the Electrical Contractor must ensure that all relevant post-connection tests have been completed and then forward results to the Council.

**Developers/Electrical Contractors should note that once an Electrical Completion Certificate has been submitted for all or a portion of any public lighting installation, no subsequent disconnection or alteration may be made to it unless specifically agreed in advance by Fingal County Council.**

**For any Council approved completion of or addition/extension to circuits already energised the Developer/Contractor must forward the appropriate Minor Works Completion Certificate to the Council to comply with CER regulations.**

### **APPLICABLE INSTALLATION STANDARDS AND CODES OF PRACTICE**

Erection and testing details shall be in accordance with the current editions of and amendments to:

- (a) ET 101:2008 National Rules for Electrical Installations Fourth Edition, including all Amendments.
- (b) ET211/2003: Code of Practice for Public Lighting Installations in Residential Areas.
- (c) National Code of Practice for Customer Interface, as published by ESNB.
- (d) Code of Practice for the Erection of Street Lighting Equipment, published by the Association of Street Lighting Contractors, England.

The Electro-Technical Council of Ireland publishes documents (a) and (b).

### **INSTALLATION DETAILS**

#### **ALL PUBLIC LIGHTING PILLARS, COLUMNS, DUCTS AND CABLES MUST BE PLACED OUTSIDE THE BOUNDARIES OF PRIVATE PROPERTY.**

**If there is any doubt as to the exact location of columns/pillars, or any difficulty in placing columns/pillars or arranging cable circuits according to the layout provided, or if the Developer changes the site/roads layout, the PLS must be consulted to agree any consequential alterations to the lighting design before work is carried out. Otherwise the Council may not accept the altered installation and may require other changes to be carried out at the Developer's expense to provide a compliant arrangement.**

#### **Columns**

Column construction shall comply with IS EN 40 and designed to suit topography/'k' factor appropriate to Irish conditions and will normally be planted root style. The column baseboard access door shall be centred at a height of 1.5 metres above finished road level. A cable entry slot, 150 mm. x 75 mm., reinforced if necessary, shall be provided in the column root in line with the compartment door ope and the top of the entry shall be a minimum of 300mm below ground level when installed.

Each column and door shall be basically protected against corrosion by hot dip galvanising after manufacture complying with BS EN ISO 1461:2009. The outside of the planted portion of all columns shall additionally be protected by a bituminous coating extending to a height of 150mm above ground level.

All 8 and 6 metre columns shall be of tapered octagonal construction fabricated from 3mm sheet steel or of tubular steel construction with a minimum wall thickness of 3mm. No circumferential butt-welding shall be used in column fabrication.

All 12 and 10 metre columns shall be of tapered octagonal design, formed from 3mm thick sheet steel and fabricated using longitudinal welding only.

In a multi-phase development the Council may specify the use of octagonal or tubular columns in order to maintain a consistent and co-ordinated installation through the phases.

For octagonal columns, the door opening shall comprise a welded-in frame with all around weather strip and the door itself must be of flat steel and secured by 2 triangular head screws as per Drawing Number PL 1/2 Rev.2A.

In the case of tubular steel columns, a close fitted non-overlapping curved steel door may be offered as an alternative to 'frame' door secured by 2 triangular head screws.

A fireproofed insulating baseboard shall be fitted in each column base compartment suitable for mounting cable termination/looping blocks, fuse unit and cell test switch. The clearance between baseboard and the inside face of door when secured shall be not less than 100 mm.

### **Bracket Arm Details**

Where used bracket arms shall be outreach types only, normally incorporating a uplift of 0 to 5 degrees as required by lighting design and subject to maximum lengths indicated in Table 1 below. The arms shall be removable and of the sleeve fitting type, fabricated from tubular steel and after manufacture shall be basically protected against corrosion by hot dip galvanising complying with BS EN ISO 1461:2009.

Bracket arms and column shafts shall be fitted with a device to prevent rotation of the brackets in service. Eight unobtrusive socket screws shall secure each bracket arm to the column.

### **Erection of Columns and Brackets**

**TABLE 1: Standard installation arrangements of lighting columns**

<b><u>Mounting Height</u></b>	<b><u>Minimum Root Depth **</u></b>	<b><u>Std. Setback of column face from front of Kerb</u></b>	<b><u>Max. Bracket Length</u></b> ( post-top mounting may be used where appropriate)
6 metre	1.0 metre	1.5 metre	1.0 metre
8 metre	1.2 metre	2.0 metre	1.5 metre
10 metre	1.5 metre	2.5 metre	2.0 metre
12 metre	1.7 metre	3.0metre	2.5 metre

\*\*The Developer shall determine from the manufacturer/supplier of the columns if a longer rooting depth is required where bracket and lantern combination is to be used.

**IN STANDARD INSTALLATIONS THE INSTALLED COMBINATION OF COLUMN SETBACK AND BRACKET LENGTH SHALL NOMINALLY SUPPORT THE LANTERN DIRECTLY ABOVE THE ROAD KERB.**

It is preferable that columns are normally placed in roadside grassed verges at the setback indicated in Table 1 above. Where the width of the verge is less than the preferred setback, the column shall be placed in the back of the verge and the bracket arm length reduced if necessary.

In the absence of verges it is preferable that columns are placed in the back of footpaths. In cases of shared or un-kerbed surfaces the Developer shall make suitable arrangements by way of barriers/bollards or suitably sized kerbed islands to prevent columns being struck accidentally by normal vehicle manoeuvres.

In all situations and having regard to planning practice actual placement of columns shall take due account of clearances necessary to facilitate kerbside vehicle parking, normal use of cycle-ways and footpaths, and undue light trespass onto adjacent property.

Columns shall be erected by planting their root portion in excavations of suitable size and secured as shown in Drawing PL 5/1. The excavated hole must be pumped free of any water before being filled with concrete. Columns shall be erected exactly vertical in a safe and workmanlike fashion using a crane or suitable hoist. All columns shall be set such that the centre of the column door opening is 1.5 metres above finished road level and normally faced away from oncoming traffic.

Columns shall be secured by uniformly filling the excavated hole around the base of the column with concrete up to the bottom of the cable entry slot. The concrete used shall be in accordance with the Department of the Environment Specification for Road Works, Clause 1502, Concrete for Ancillary Purposes (Class E).

The final one metre of incoming and outgoing cables shall be protected by Hydrodare piping or equivalent extending 300 mm. into the column and kept level with the bottom of the entry slot to avoid cable damage due to column settlement.

**Column Numbering - Painted/Stencilled numbers are not acceptable.**

Fingal County Council will provide the numbering sequence on lighting plan. The Council will not issue TMPRNs to Developer/Lighting Contractor until the columns covered by the relevant Completion Certificate are numbered in accordance with the lighting plan and as described below.

Each column shall be numbered using white backing tape wrapped completely around the column at a height of 3 metres above ground with numbers securely affixed to this backing tape and facing the roadway. Number decals shall be white numbers, 75mm high, on a black background.

**Service-pillars**

It is envisaged that two sizes of service pillar may be required depending on the nature of the development; refer to ESB Networks Code of Practice for Customer Interface for most up-to-date requirements.

(a) **Residential Service Pillar (Unmetered Supply)**

These are usually used in Residential Roads and Local Distributor roads for single-phase supply. The Baseboard shall be adequate to accommodate ESB Single Phase 80A fused Cut-



out, and Isolator if specified by ESB Networks, together with separate Neutral and Earth Terminal link blocks and a minimum of three single phase fuse units, i.e. incoming supply and two outgoing circuits.

(b) Road Service Pillar (Metered Supply)

Usually used for higher wattage PL installations on regional roads and major traffic routes and where a 3ph supply is required. The ESB metering equipment must be physically separated from PL distribution fuses in a separate compartment of a dual compartment pillar. The Metering compartment must comply with minimum ESB Networks requirements and the PL Distribution compartment sized to accommodate appropriate fuses/isolators and Earthing and Neutral terminals appropriate to the electrical design.

In order to avoid possible delays in completion of connections by ESB Networks, Fingal County Council strongly recommends that the Developer, or his PL Contractor, discuss directly with ESB Networks the minimum size of pillar space to be allocated for the fitting of any Networks equipment.

All service pillars shall be fabricated from 3mm. thick sheet steel including the door and extension plates. Extension plates shall be provided at the bottom of the pillar to enable firm cementing into the ground. Ground level shall be clearly marked. Each pillar shall be adequately ventilated by means of a set of louvred slots near the top. Each pillar shall be secured against unauthorised access by a single unhinged flat plate door secured with one or more triangular-head locking bolts. Each pillar and its door shall be finished for outdoor use by hot dip galvanising in accordance with BS EN ISO 1461:2009. In addition the extension plates shall be protected below ground by a bituminous coating extending all round to the level of the door recess.

An insulating fireproofed baseboard, approximately 20mm. thick, shall be fitted in each pillar to facilitate mounting of supply cut-out and isolator, link blocks, fuse-units and any other specified equipment. All brass and metal components shall be electro-plated. The pillar shell shall have an earth bonding post.

The service pillars shall be secured by placing concrete complying with Department of the Environment Specification for Road Works, Clause 1502, Concrete for Ancillary Purposes (Class E) around the base of the extension plates. This concrete must not enclose any cables.

**Underground Ducts.**

Public lighting installations are powered by looping cables underground in ducts from column to column on their appropriate circuits and terminating in link blocks in the base of each column and service pillar.

**ALL DUCTS SHALL BE PLACED OUTSIDE THE BOUNDARIES OF PRIVATE PROPERTY AND MUST NOT AT ANY TIME PASS THROUGH ESB OR TELECOMMS CHAMBERS. THE ONLY DUCT THAT SHALL ENTER AN ESB CHAMBER IS THE LINK DUCT BETWEEN THE ESB NETWORK LT PILLAR AND THE PL SUPPLY POINT PILLAR.**

Duct shall be High Density polythene pipe to I.S.135 Class B or PVC type complying as a minimum with IS EN 61386-24:2010 having a 750N load rating for 5% deflection. Cable ducts shall be **RED** in colour and stamped with the legend 'public lighting duct', the initials PL or otherwise identified to clearly distinguish them from other electrical cable ducts.

In residential developments ducts run in verges and footpaths are nominally 50mm diameter. A spare 50 mm. duct shall be laid across all driveway aprons. Cables shall be run in 100 mm.

diameter PVC duct at road crossings. A spare 100mm duct shall also be provided at such crossings.

Ducts shall be laid in fully coupled unbroken lengths at the appropriate depths specified in ET 101/2008, Table 52B and section 522.6.8. In all situations an Electrical Hazard warning tape, as per ET 101/2008, shall be laid at the appropriate depth directly above the cable duct.

**A Supply Point Duct Completion form shall be submitted with each ETCI Completion Certificate relating to a new supply connection for each PL Supply Point Pillar; otherwise Fingal County Council will not process the connection order and will return the Completion Certificate(s) to the Developer/Contractor.**

### **Underground Cables**

Underground cables shall preferably be NYCY complying with DIN VDE 0271, or alternatively PVC/SWA/PVC to BS 6346. Where SWA-type cable is used, the cable shall include a Protective Conductor core and at each column/pillar the steel armour shall be clamped onto suitable collars and bonded to the earth block via a 10-sq. mm. copper earth wire.

For standard residential installations single-phase circuits will normally be used and cables will normally be 2x6-sq. mm. NYCY type. On major distributor roads, conductor size may be larger and 4/5 core cable may be specified to utilise a three-phase supply; verge/footpath duct size may also be increased to 100mm and such requirements will be shown on the Council's Public Lighting Plan.

Cable joints are not permitted in any new development. Cables shall be looped from column to column on each circuit. If faults develop on service cables before commissioning/taking in charge of the development, the section of cable involved shall be replaced and not jointed. Where existing lighting cables are affected by a new development prior agreement must be made with the Council on any modifications. In rare situations where cable joints are allowed, only resin based cable joint kits such as 3M or Scotch-Cast are to be used. Heat shrink joints are not permitted.

### **Earthing and Bonding**

A hot dip galvanised-steel earth rod at least 16 mm. in diameter shall be driven vertically into the ground to a minimum depth of 1200mm. adjacent to each service pillar. Earth rods shall be installed with a suitable inspection box allowing access to the earth conductor connection to the rod. An insulated 10 sq.mm. stranded copper earthing conductor shall be connected through a short length of duct between the Main Earthing Terminal in the Service Pillar and the earth rod. The ends of this duct shall enter both the inspection box and the Service Pillar.

In all columns and pillars metalwork shall be bonded to the earth terminal via a 10 sq. mm. stranded copper conductor fitted with a crimped lug for attachment to the bonding post.

### **Luminaires**

Only LED luminaires shall be used on public lighting installations. The use of ground floodlights, recessed up-lighter luminaires and bollard lighting is not permitted.

Fingal County Council is on a framework for the procurement of LED luminaires for both residential and distributor roads. Based on this framework, the approved list of LED luminaire manufacturers are:

- a. CU Phosco Lighting
- b. Holophane Lighting
- c. OrangeTek Lighting
- d. Philips Lighting
- e. Swarco
- f. Urbis Schröder Ltd
- g. ZG Lighting Ltd (formally Thorn Lighting Ltd)

LED luminaires which are not manufactured by the above may also be used in new installations but must comply with the specifications of the framework-available on request. The Developer must submit data for the proposed fittings on the LED Data Form included with this document.

Each lantern shall be fitted with a 7 pin NEMA-type socket for mounting of a Photoelectric Control Unit (PECU) unless otherwise directed by the Engineer. The socket shall be fitted with a watertight gasket and secured by 4 non-corrodible screws that shall maintain the IP rating of the canopy. The NEMA socket shall be wired to the lantern control circuit.

### **Light Level Control**

All luminaires shall be programmed with Constant Light Output (CLO) as standard and shall be dimmed to 75% CLO output between mid-night and 6.a.m.

### **Switching Control**

Standard switching control of public lighting systems is achieved by means of electronic photocells which operate from dusk to dawn, based on 35/18 lux trigger level. The Council may specifically indicate a requirement for a different trigger level and remotely monitored units as part of its programme for energy management and fault monitoring.

An individual solid-state one-part Photo-Electric Control Unit, PECU, which shall include a “fail safe” circuit that switches the lantern on in the event of photocell failure, shall control each lantern. The PECU must comply with BS 5972 and shall incorporate a phototransistor complying with I.S.428: 1991 as the light sensor. The unit shall have a guaranteed manufacturer’s **warranty period of at least 6 years**. The PECU shall be designed for mounting in the NEMA socket provided on each lantern housing. A test switch shall be provided in the base compartment of each column for daytime testing by short-circuiting the photoelectric cell.

### **Main Circuit Fuses**

Main circuit fuse units shall be mounted on the baseboard in the Service Pillars. They shall be of the HRC cut-out type complying with the latest version of B.S.88. Fuse bases shall be sized to accept termination of the full incoming/outgoing conductor cross-section. The Fuse Links shall be appropriately rated for the cable size and loading of the relevant circuit.

### **Link Blocks**

Link blocks are used for the termination of all conductors of underground cables in columns and shall also be used as the Main Earth/Neutral Terminals in all columns and pillars. Link blocks shall be BICC 63 Amp type, or approved equivalent. They shall be fully insulated and securely fixed with brass woodscrews to the column and service pillar baseboards. The holes in the cable termination block shall have a serrated inner surface for good conductor contact and the metal block shall be

positively retained within its insulated base when the cover is removed. In addition the link block cover shall have a retaining strap to prevent the cover falling into the root of the column.

### **Column Baseboard Electrical Components (Ref. Drawing PL 10A)**

All electrical equipment located in the column baseboard compartment shall have at least the degree of protection IP33, either by construction or installation, as required by ET101. All equipment shall be securely mounted with brass woodscrews.

The equipment shall normally include:

- Termination Blocks/Cut-outs for underground supply cables and earthing.
- 1-phase fuse unit for the column control circuit.
- Test Switch to enable bypassing of Photocell.

The equipment shall be arranged as per one of the following appropriate options.

(a) **6 metre columns (Single phase system)**

Three possible arrangements of equipment are acceptable

- (1) Incoming and outgoing cables may be terminated in **three** 63 Amp BICC type link blocks as described above, being assigned to Phase, Neutral and Earth/Screen. and
- A separately mounted column fuse unit suitable for a BS88 fuse or a Neozed fuse to DIN VDE 0636, rated 6 Amps.
  - and
  - A separately mounted architrave-type switch for bypassing the PECU.

**or**

- (2) Incoming and outgoing cables may be terminated in a suitable single phase Street Lighting Cut-out, e.g. Lucy MC040SLE, or equivalent to comply with BS 7654 as agreed with in advance with Fingal County Council, incorporating **three terminals**, being assigned to Phase, Neutral and Earth/Screen, and including an integral column fuse unit suitable for a BS88 fuse or a Neozed fuse to DIN VDE 0636, rated 6 Amps. and
- A separately mounted architrave-type switch for bypassing the PECU.

**or**

- (3) Incoming and outgoing cables may be terminated in **three** 63 Amp BICC type link blocks as described in (a) above, being assigned to Phase, Neutral and Earth/Screen.
- and
- An enclosure of heavy-duty plastic incorporating a fuse unit, test switch and earth and neutral terminals as detailed in (b) below.

(b) **8m/10m columns (Single and Three phase systems)**

Incoming and outgoing cables shall be terminated in **three/five** 63 Amp BICC type link blocks as described above, with one block per phase, Neutral and Earth/Screen.

and

An enclosure of heavy-duty plastic rated IP 54, such as Hager C303U/PLU or approved equivalent, shall be provided for the fuse and test switch. This unit shall be sized to accommodate three 17.5mm wide modular units and shall house the following items: -

Isolating Fuse Carrier with 6A fuse to BS 88. e.g. Hager L501 or equivalent.

Photocell Test Switch. e.g. Hager NI16 or equivalent.

A DIN-rail mounted Earth Terminal sized for 10 sq.mm.

A DIN-rail mounted Neutral Terminal sized for 10sq.mm.

Any unused ways shall be blanked off.

The fuse and switch shall be clearly identified with a permanently fixed engraved "Traffolite" label.

Cable entry to the enclosure shall be via PG glands, or equivalent, which shall maintain the IP54 rating of the enclosure.

### **Column Internal Cabling**

The earth continuity conductor for the lantern shall be 2.5 sq.mm. PVC single core stranded copper conductor coloured in accordance with ET 101. All other circuit cables shall be 2.5 sq.mm. PVC/PVC single core cable with stranded copper conductors. Alternatively a single 4-core Heavy Duty PVC/PVC flexible cable with 2.5 sq.mm stranded copper conductors may be utilised.



### LED LUMINAIRE TECHNICAL DETAILS

Luminaire Manufacturer, Make & Model			
LED Module Manufacturer			
Luminaire Design Life	>10		yrs
No. LEDs in Luminaire			
Driver Manufacturer			
Proposed Driver Current			mA
Driver Design Life	>10		yrs
Weight of complete luminaire	>10		kg
Angles of tilt available			deg (°)

Rated Input Power (LM-79 report)			W
Total CLO Circuit Watts of Luminaire (LEDs + Driver)			W
Power Factor - min. 0.92 (LM-79 report)	min. 0.92		
Surge Protection Rating (IEC 61643-11)	10kVA/6kV		

Lamp Lumen Maintenance Factor (LLMF)			
Lamp Survival Factor (LSF)			
IP Rating - Optical Compartment	65		
IP Rating - Gear Compartment	65		
IK Rating - Impact	08		

S/P Ratio			
Risk Group Classification in accordance with EN 62471			
CCT (LM-79 report)	< 4000		K
CRI - Ra value (LM-79 report)	> 60		
Glare Class			
ULOR (Upward Light Output Ratio)	< 1%		%
Luminaire Luminous Efficacy (LM-79 report)			Lm/W
Initial Luminaire Lumen Output (LM-79 report)			Lm
% Maintained Luminaire Lumen Output @6,000 hrs (TM-21 report)			%
Rated Life at L90B10 (TM-21 report)			hours

These cells indicate Target/Preferred Values



PL Designer/Contractor:

Date:

REV	DESCRIPTION	DATE

**NOTES**

**GENERAL**

- (1) ALL DIMENSIONS IN MILLIMETRES UNLESS OTHERWISE STATED.
- (2) FIGURED DIMENSIONS ONLY—DO NOT SCALE.

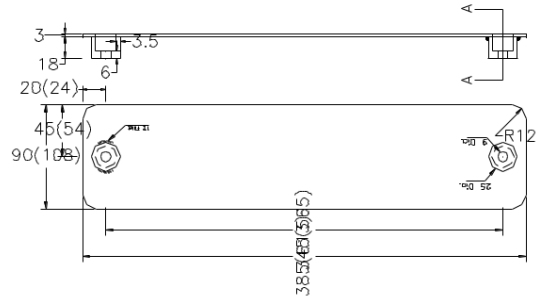
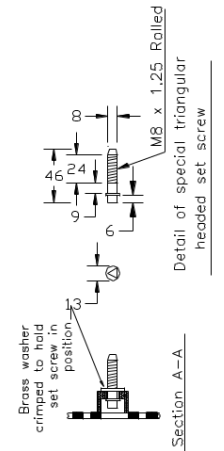
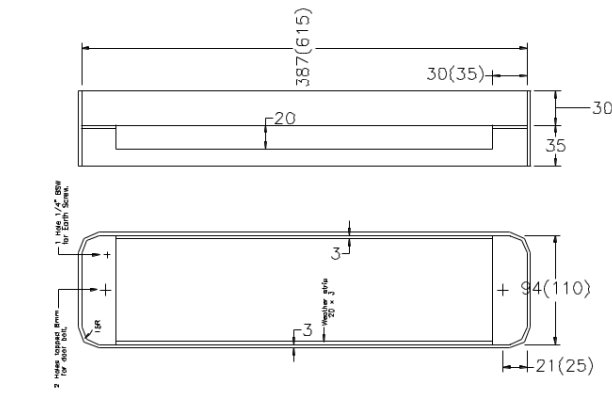

**COMHARLE CHONTAB PEINE GALL**  
FINGAL COUNTY COUNCIL

ALDERMAN DEPARTMENT  
BROVE ROAD  
BLANCHRISTOWN  
TEL. 8958356  
FAX 8958329

DRG. NO. RL 1/2  
REV. 24

SCALE 1:1.5  
DRAWN BY  
TECH. LEADER AC  
DATE 27/04/2000

TITLE  
DOOR AND FRAME DETAILS FOR 12M, 10M,  
8M & 6M LIGHTING COLUMNS.

**Materials**  
Cover plate mild/steel galvanised.  
Set screw stainless steel.  
Retaining washer brass.  
Finished dimensions of door shall include galvanised coating or equivalent.  
Dimensions in brackets relate to 12m, 10m, & 8m columns only. All other dimensions are common to both sizes.

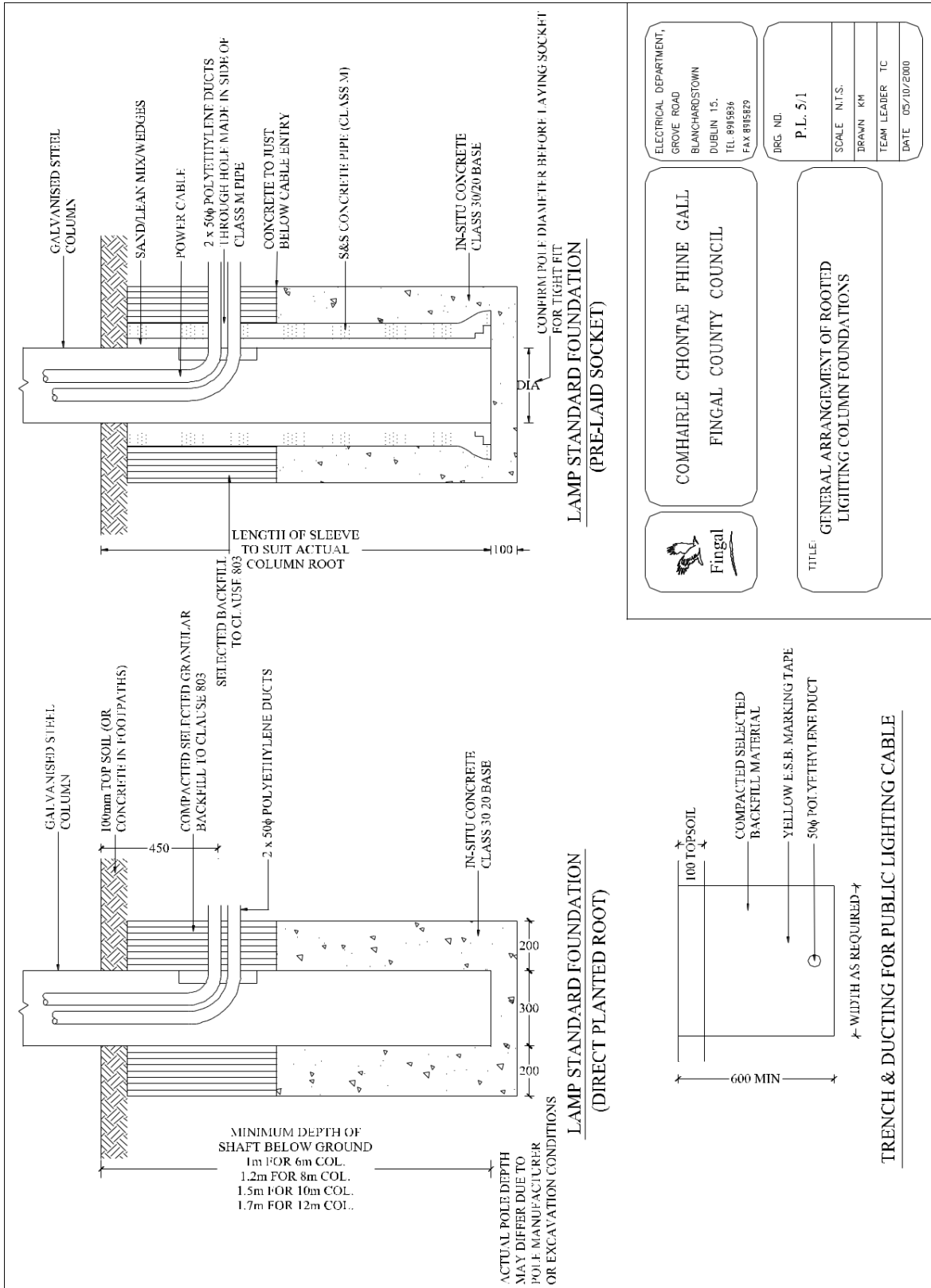

ELECTRICAL DEPARTMENT,  
GROVE ROAD  
BLANCHARDSTOWN  
DUBLIN 15.  
TEL: 8965836  
FAX: 8965829

COMHAIRLE CHONTAE FHINE GALL  
FINGAL COUNTY COUNCIL



DRG. NO.  
P.L. 5/1  
SCALE: N.T.S.  
DRAWN: KM  
TEAM LEADER: TC  
DATE: 05/10/2000

TITLE:  
GENERAL ARRANGEMENT OF ROOTED  
LIGHTING COLUMN FOUNDATIONS



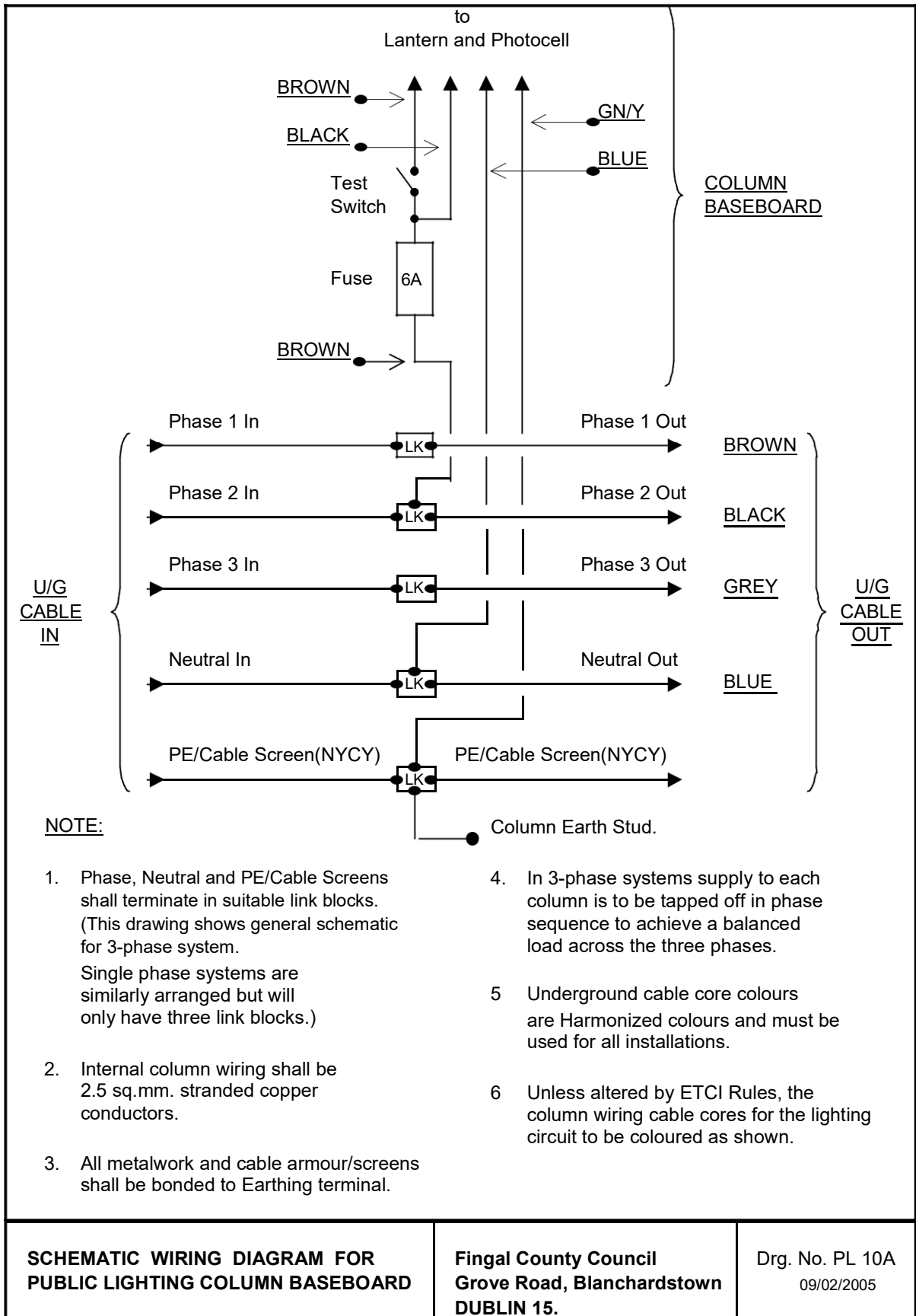

**To: - Public Lighting Section**  
Transportation Department  
Fingal County Council

**SUPPLY POINT DUCT COMPLETION FORM**

RECI Completion Cert Number: \_\_\_\_\_ Date: \_\_\_\_\_

Link Duct from ESB LT Pillar to Supply Point Pillar is complete, clear of obstruction and roped.

Signed: \_\_\_\_\_

Company: \_\_\_\_\_

**NOTE:**

‘Complete’ means duct is properly coupled into a continuous run, is clear and roped, with the mouth at each end of the run entered into the pillars.

Comment/Instructions:

# Public Lighting (PL) Flowchart

